

# examinetics

insightXonsite

Supporting



the health



of America



at work



Effective solutions in occupational health

# examinetics

insightXonsite

## Corporate Office

Examinetics, Inc.  
10561 Barkley Place  
Suite 400  
Overland Park  
KS 66212

Toll Free - 800.946.7228  
Phone - 913.748.2000  
Fax - 913.748.2001  
Email - [Sales@examinetics.com](mailto:Sales@examinetics.com)  
Web - [www.examinetics.com](http://www.examinetics.com)



## Who We Are

**Examinetics** is the nation's largest provider of onsite occupational health screening and data management services. Our fleet of over 75 mobile units provides our clients with flexibility nationwide, consistent application of protocols and easy consolidation of all data.

We serve over 2,000 clients at more than 8,000 locations.

We employ over 225 people, including in-house audiologists and other occupational health specialists.

At Examinetics we are totally focused on client service. Above all, we never forget that we exist to make our clients' lives easier.

## Our Services

**Examinetics** offers a wide range of occupational health screening, compliance and wellness programs, specifically designed to reduce the ever-increasing burden of regulation and legislation.

Through the experienced application of each of these services, we are committed to meeting all your needs and exceeding your expectations.

### Our Competitive Advantages

- Nationwide Consistency and Coverage - at your site
- Web-based data management excellence
- Expertise and experience
- Effective occupational health solutions
- Licensed healthcare professionals are part of our full-time staff

To achieve **insight** at your site, contact us at:  
**913.748.2000** or **sales@examinetics.com**

# Our Services Include:

## Hearing Conservation

- Audiometric Testing
- Audiometric Training & Counseling
- Hearing Conservation Program Management
- On-line Audiological Review and Reporting
- Work Relatedness Determination

## Health Screening

- Physical Examinations
- Pulmonary Function Screening
- EKG's & Chest X-Rays
- Blood Tests & Urinalysis
- Vision Screenings
- Full Program Management
- Annual Corporate Reviews

## Clearance Programs

- Respiratory Protection
- Qualitative & Quantitative Fit Testing and Training
- Hearing Conservation
- HazMat
- Asbestos
- DOT Exams
- Online Respirator Clearance

## Health Promotion / Wellness

- Health Risk Assessment
- Screening / Counseling



To achieve **insight** at your site, contact us at:  
**913.748.2000** or **sales@examinetics.com**

# Our Fleet

Examinetics will respond to all your workforce and scheduling requirements, utilizing the largest and most flexible fleet of mobile occupational health screening units in the nation. By bringing the testing unit to the workplace, Examinetics can deliver occupational health programs at a significant cost savings to you.

- 2 back-up audiometers per unit
- Quantitative fit test equipment & spirometers on each unit
- Sound level meters
- Air-conditioned/Heated/Ventilated reception area and sound booths
- 110V / 20A power

## 4-Man Audio Unit

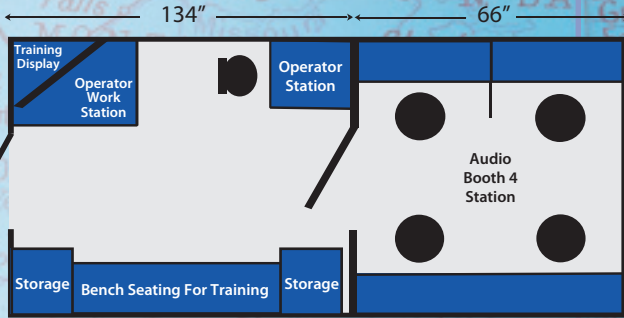

## 8-Man Audio Unit

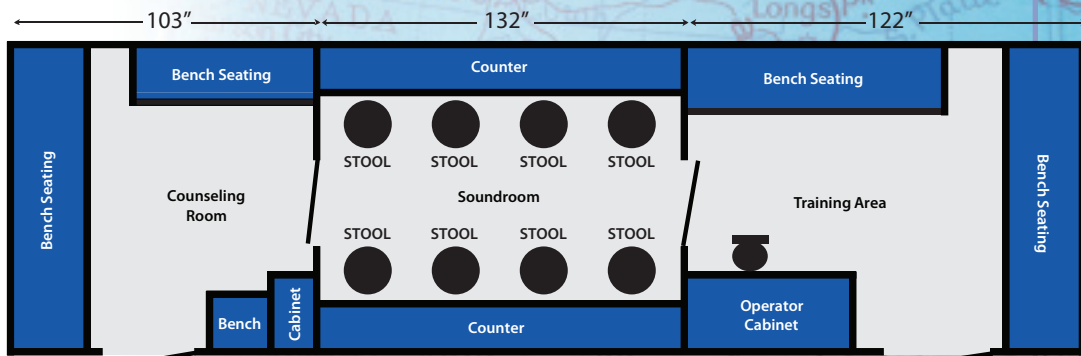

## Health Screening Facility

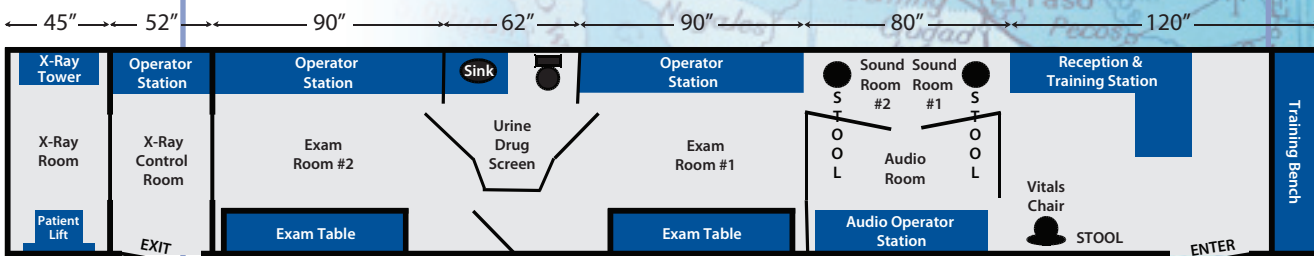

- Fully-equipped mobile occupational health facility
- Compartmentalized testing rooms
- Multiple audio booths
- On-board computers with proprietary software
- On-board X-ray processing
- On-board bathrooms
- Operation using shore power or on-board generators

# Our Technology

## XM Solutions

XM Solutions is the Examination Management Network for the occupational health industry.

XM Solutions is a patent-pending, fully Internet-enabled, HIPAA compliant, occupational health data management and reporting system.

Using the power of the Internet, XM Solutions is designed to deliver to you a secure and compliant data control and management system, via an intuitive, easy-to-use interface, supported by a wealth of reporting options to suit your needs.

Other data management features include:

- Import and management of audiological test data from remote data collection systems
- Integrated employee & demographic data in a single system
- Full data export in CSV, Excel or other customer-specific formats
- Corporate and Divisional Reporting Levels

### **XM Solutions is made available to all clients of Examinetics.**

Examinetics is committed to a continual and constant investment program to ensure that new features and functionality are regularly implemented within XM Solutions, all designed to make your life easier.

To achieve **insight** at your site, contact us at:  
**913.748.2000** or **sales@examinetics.com**

# Online Reports

At the click of a button, **XM Solutions** now provides you with a comprehensive list of individual and summary reports in various languages.

## Employee Specific Reports

- Audiologist Review by Individual
- Hearing Test History by Individual
- Notification Graph by Individual
- Participant Exam Comp Data
- Respirator Fit Card

## Event Reports

- Audiologist Review by Event
- Clearance Summary by Event
- Client/Facility Comp Data
- Hearing Test History by Event
- Notification Graph by Event

## Summary Reports

- Aggregate Summary
- Alphabetical Listing of Employees
- Audiologist Review Summary
- Audio Test Cards Bilingual
- Audio Test Cards English
- Audio Test Cards Entered by Portal
- Custom STS Retest
- Employees Not Tested
- Impairment Reports
- Medical Clearance Alpha List
- Medical Clearance Listing with Fit Test Results
- Medical Clearance Summary
- Near Recordable Shifts
- Recordable Shifts
- Shift Follow up Report
- Statistical Summary
- Vision Summary Report



To achieve **insight** at your site, contact us at:  
**913.748.2000** or **sales@examinedics.com**

# examinetics

insightXonsite

Nationwide consistency

Data management excellence

Expertise and experience

Effective solutions in occupational health

## Corporate Office

Examinetics, Inc.  
10561 Barkley Place  
Suite 400  
Overland Park  
KS 66212

Toll Free - 800.946.7228  
Phone - 913.748.2000  
Fax - 913.748.2001  
Email - [Sales@examinetics.com](mailto:Sales@examinetics.com)  
Web - [www.examinetics.com](http://www.examinetics.com)

